

LIQUID RING VACUUM PUMPS

Two Stage

GVP 230/120 - GVP 230/160 - GVP 230/220

Pressure Range : 33 - 1013 mbar

Suction Capacity : 175 - 450 m³/h



GÜCÜM Two Stage Liquid Ring Vacuum Pumps are used for pumping dry and wet gases, small quantities of liquid can be handled. They are used in the areas at which vacuum needed between the pressures 1013 to 33 mbar.

GÜCÜM Two Stage Liquid Ring Vacuum Pumps have the below features:

- * Able to pump every kind of gases and vapours,
- * Able to handle small quantities of liquid with gases,
- * Oil-free, no need to lubrication,
- * Pumped gas do not touch the oil,
- * Minimum maintenance with high efficiency,
- * No metallic contact of the rotating parts,
- * Shaft not contact with the medium,
- * Works quiet and reduced vibration,
- * Nearly everywhere used with suitable material choices.

Service Liquid

During pump working, service liquid must be supplied to replenish the liquid ring and to cool the pump (generally water is used). The exhausted liquid could be used again after separating the gas inside of it.

The direction of the rotation is clockwise, when looking from the motor on the pump.

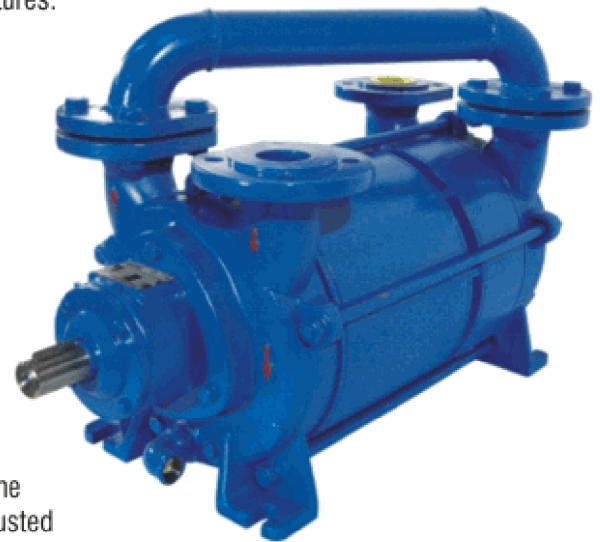

TECHNICAL PROPERTIES

Properties	Unit	GVP 230/120	GVP 230/160	GVP 230/220
Motor Power	kW	11	11	15
Motor Speed	rpm	1450		
Max. Service liquid flow	lt/min	30	35	45
Max. Admissible pressure difference	bar	1,1		
Max. Gas temperature	°C	100		
Max. Service liquid temperature	°C	70		
Max. Service liquid viscosity	mm ² /s	4		
Sound pressure level (at 80 mbar suc. pressure)	dB A	66 ±3		
Max. Service liquid density	kg/m ³	1200		
Max. Flow resistance of the heat exchanger	bar	0,2		

OVERALL DIMENSIONS

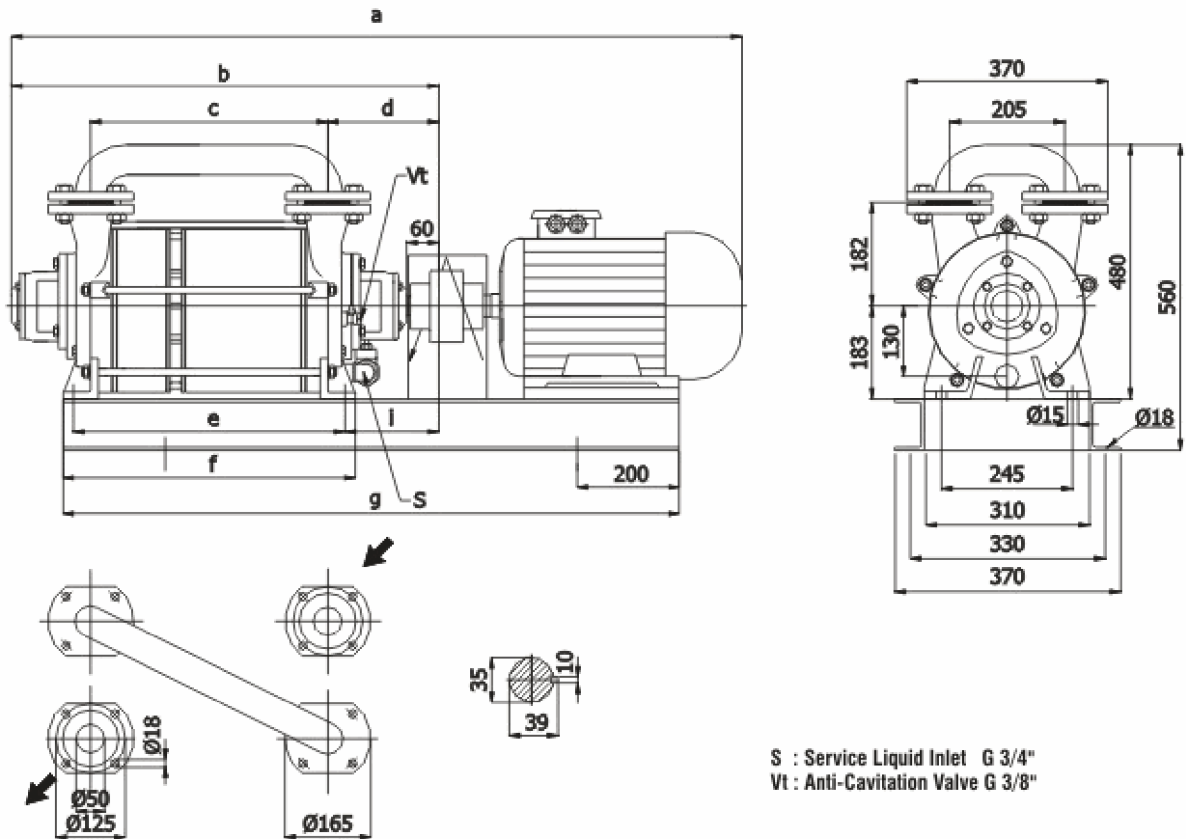

MODEL	a	b	c	d	e	f	g	i	Weight (bare shaft) kg	Weight (complete with motor) kg
GVP 230/120	1225	710	330	220	400	440	975	185	140	230
GVP 230/160	1395	770	390		460	500	1125		156	300
GVP 230/220	1510	840	460		530	570	1260		175	350

MATERIALS

Part Name	Standard Construction	Stainless Steel Construction
Suction&Discharge Casing	GG 25 Cast Iron	AISI 304-AISI 316 St. Steel
Plates	GGG 40 Sph. Cast Iron	AISI 304-AISI 316 St. Steel
Body	GGG 40 Sph. Cast Iron	AISI 304-AISI 316 St. Steel
Shaft	AISI 420 Stainless Steel	AISI 304-AISI 316 St. Steel
Impellers	G Cu Sn 9 Bronze	AISI 304-AISI 316 St. Steel
Mechanical Seal	Si. Carbide/ Carbon/Viton	Cr Ni Mo Steel/Carbon/Viton

SECTIONAL DRAWING AND PART LIST

GVP 230/120 - GVP 230/160 - GVP 230/220

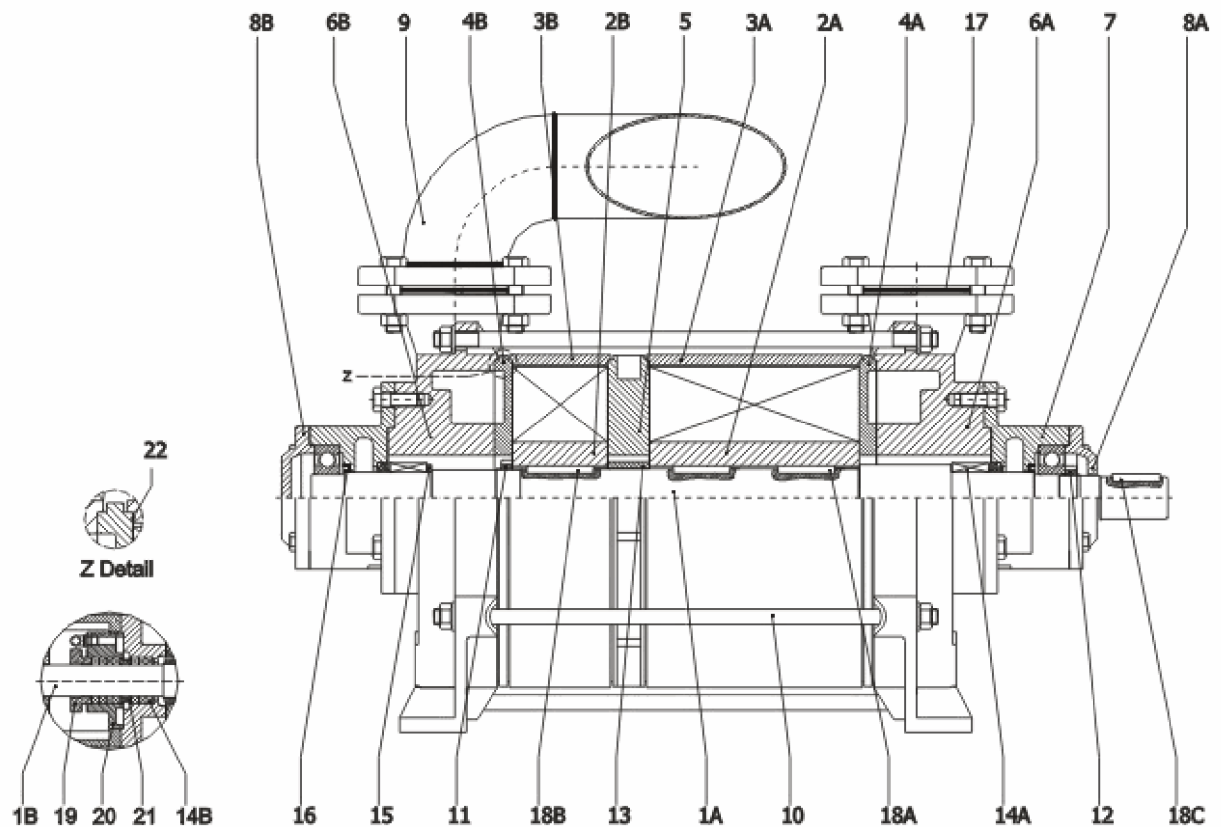

No	Part Name	No	Part Name
1A	Shaft (Mechanical Seal)	11	Impeller Nut
1B	Shaft (Soft Packing)	12	Bearing Nut
2A	First Impeller	13	Impeller Spacer
2B	Second Impeller	14 A	Mechanical Seal
3A	First Casing	14 B	Soft Packing
3B	Second Casing	15	Mech. Seal Spacer
4A	Suction Plate	16	O-ring
4B	Discharge Plate	17	Gasket
5	Intermediate Plate	18 A	First Impeller Key
6A	Suction Casing	18 B	Second Impeller Key
6B	Discharge Casing	18 C	Coupling Key
7	Bearing Carrier	19	Gland
8A	Bearing Cover	20	Stuffing Box
8B	Bearing End Cover	21	Lantern Ring
9	Branch Pipe	22	Paper Gasket
10	Tie Rod		

CHARACTERISTIC CURVES

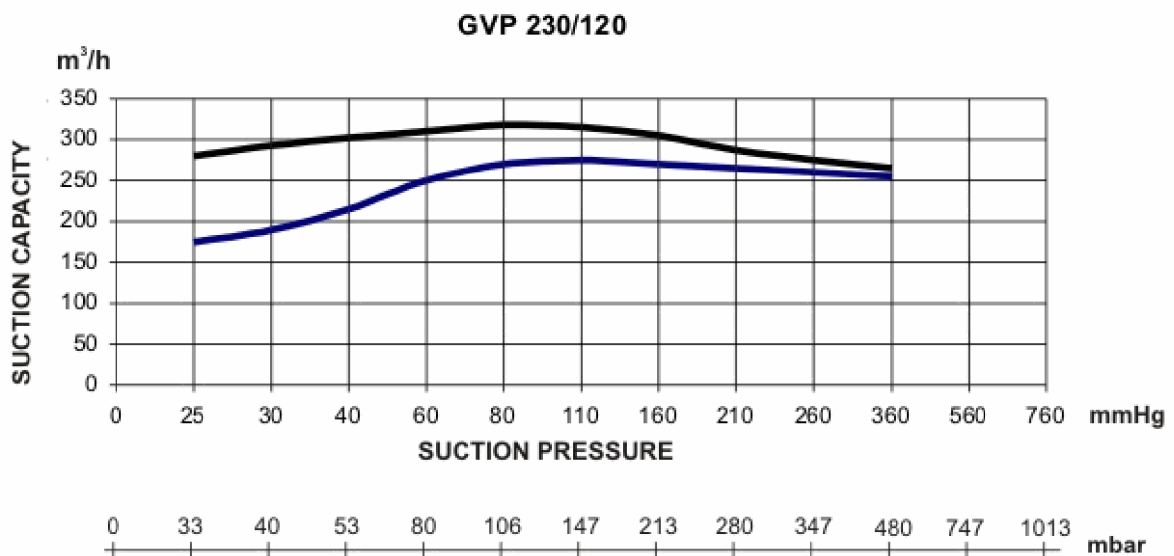
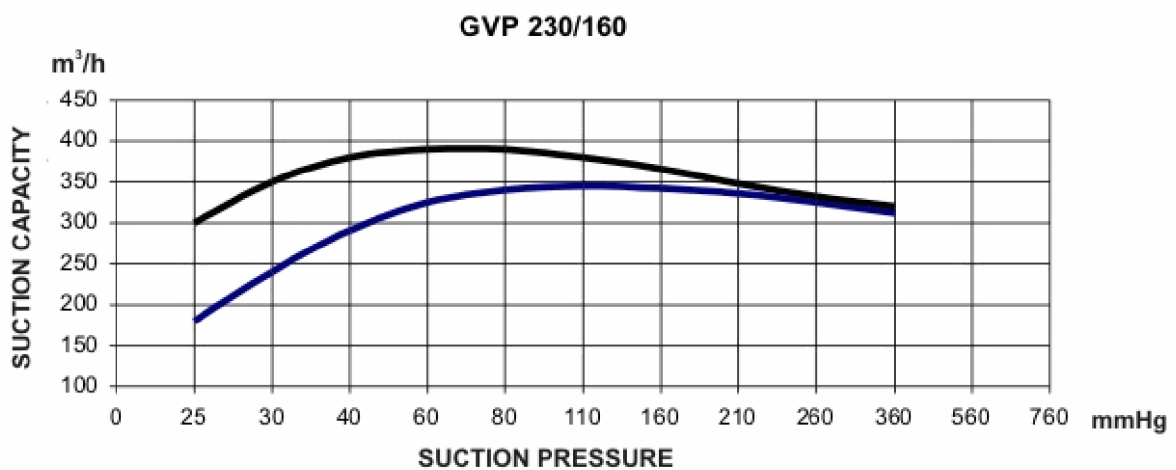
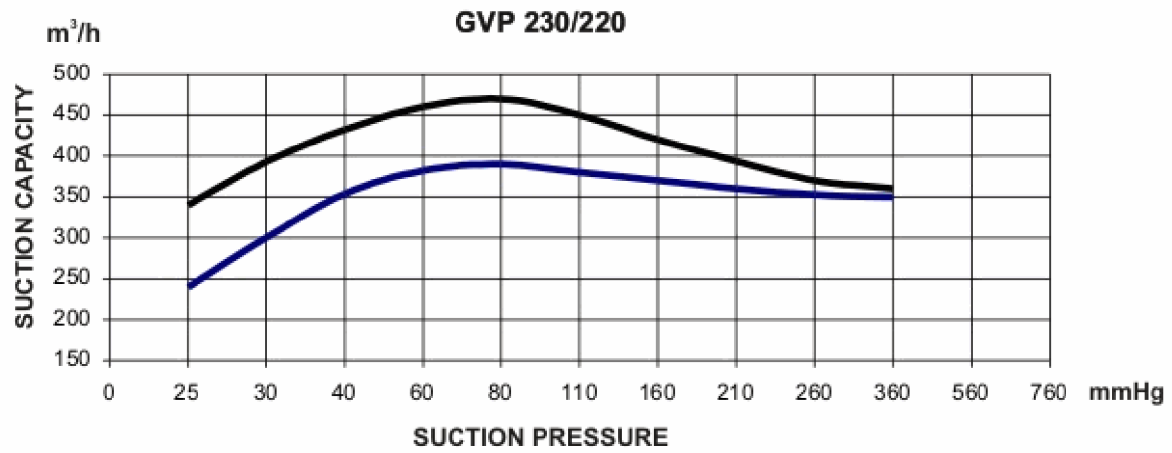

20 °C water vapour saturated air
 20 °C dry air

The capacities shown at the graph are for 760 mmHg atmosphere pressure and service liquid temperature 15 °C . Tolerance of the curves are 10% .