

LIQUID RING VACUUM PUMPS

GMP 250/160 – GMP 250/200 – GMP 250/240

PRESSURE RANGE : 33 – 1013 mbara / 0.98 – 30 inHg

SUCTION CAPACITY : 300 – 685 m³/h / 176 – 403 cfm

GÜCÜM two stage liquid ring vacuum pumps are used for pumping dry and wet gases, small quantities of liquid can be handled. They are used in the areas at which vacuum needed between the pressures 1013 to 33 mbar

Güçüm Two stage liquid ring vacuum pumps have below features;

- Able to pump every kind of gases and vapors,
- Able to handle small quantities of liquid with gases,
- Oil-free, no need to lubrication,
- Pumped gas does not touch to oil,
- Minimum maintenance with high efficiency
- No metallic contact of the rotating parts,
- Works quiet and reduced vibration,
- Nearly everywhere used with suitable material choices.



APPLICATION

Pumps are used for the discharge of dry and humid gases (containing vapor) and a certain amount of water. It can be used in all areas where absolute pressure between 1013 and 33 mbar is required.

ADDITIONAL NOTE

During operation, the pump must be continuously supplied with liquid (usually water) to replenish the water from the exhaust line and to reduce the pump temperature. The water discharged from the pump is separated from the gas and is suitable for reuse.

The direction of shaft rotation is clockwise when viewed from the motor side.

The tightness is ensured by a standard mechanical seal.

| TECHNICAL FEATURES | | |
|---|-------|----------------------|
| Maximum allowable pressure differential | 1.1 | bar |
| Highest saturated air temperature | 100 | °C |
| Highest dry air temperature | 200 | °C |
| Highest service water temperature | 70 | °C |
| Highest service water viscosity | 4 | mm ² /sec |
| Noise level (at 80 mbar vacuum) | 76 ±3 | dB A |
| Highest density of service water | 1200 | kg/m ³ |
| Highest heat exchanger flow resistance | 0,2 | bar |

OVERALL DIMENSIONS

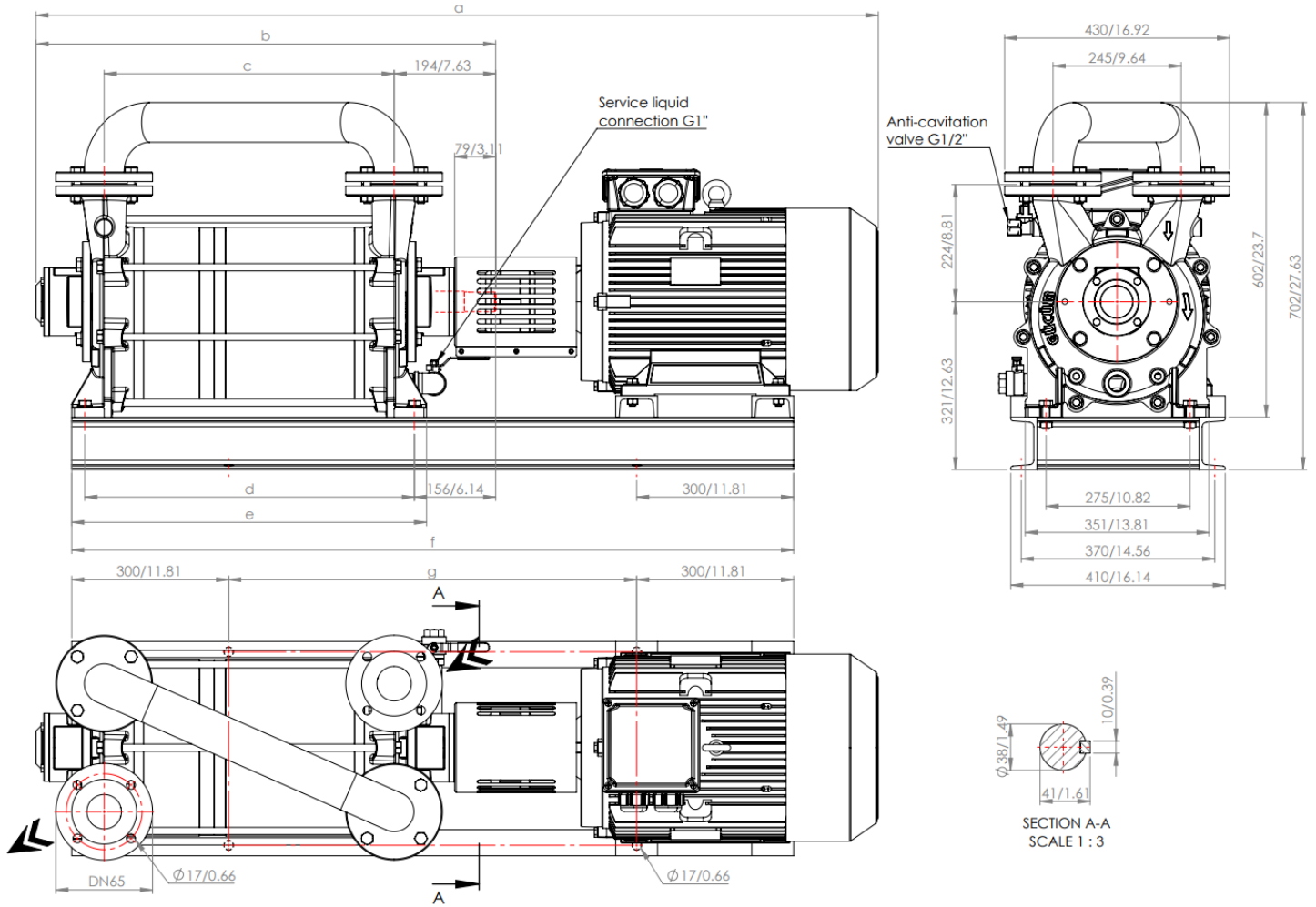

| MODEL | 50 Hz. | a | b | c | d | e | f | g | Weight (kg / lbs) | |
|-------------|--------|--------------|-------------|-------------|-------------|-------------|--------------|-------------|-------------------|------------|
| | | mm / inch | | | | | | | Bare Shaft | With Motor |
| GMP 250/160 | | 1475 / 58.07 | 799 / 31.45 | 474 / 18.66 | 550 / 21.65 | 598 / 23.54 | 1260 / 49.60 | 660 / 25.98 | 205 / 452 | 355 / 783 |
| GMP 250/200 | | 1570 / 61.81 | 839 / 33.03 | 514 / 20.23 | 590 / 23.22 | 638 / 25.11 | 1300 / 51.18 | 700 / 27.55 | 223 / 492 | 400 / 882 |
| GMP 250/240 | | 1610 / 63.38 | 879 / 34.60 | 554 / 21.81 | 630 / 24.80 | 678 / 26.69 | 1380 / 54.33 | 780 / 30.70 | 238 / 525 | 430 / 948 |

| MODEL | 60 Hz. | a | b | c | d | e | f | g | Weight (kg / lbs) | |
|-------------|--------|--------------|-------------|-------------|-------------|-------------|--------------|-------------|-------------------|------------|
| | | mm / inch | | | | | | | Bare Shaft | With Motor |
| GMP 250/160 | | 1490 / 58.66 | 799 / 31.45 | 474 / 18.66 | 550 / 21.65 | 598 / 23.54 | 1260 / 49.60 | 660 / 25.98 | 205 / 452 | 380 / 838 |
| GMP 250/200 | | 1570 / 61.81 | 839 / 33.03 | 514 / 20.23 | 590 / 23.22 | 638 / 25.11 | 1340 / 52.75 | 740 / 29.13 | 223 / 492 | 410 / 904 |
| GMP 250/240 | | 1690 / 66.53 | 879 / 34.60 | 554 / 21.81 | 630 / 24.80 | 678 / 26.69 | 1420 / 55.90 | 820 / 32.28 | 238 / 525 | 495 / 1091 |

| Motor Specifications | | | | | | | | | | |
|----------------------|--------------------------|--|--------------------------|--|-------|------|----|-------|------|----|
| Type | 50 Hz | | 60 Hz | | 50 Hz | | | 60 Hz | | |
| | Frame Size – Flange Type | | Frame Size – Flange Type | | rpm | kW | HP | rpm | kW | HP |
| GMP 250/160 | 160L – B3 | | 180M – B3 | | 1450 | 15 | 20 | 1750 | 18,5 | 25 |
| GMP 250/200 | 180M – B3 | | 180L – B3 | | 1450 | 18,5 | 25 | 1750 | 22 | 30 |
| GMP 250/240 | 180L – B3 | | 200L – B3 | | 1450 | 22 | 30 | 1750 | 30 | 40 |

EXPLODED VIEW AND PART LIST

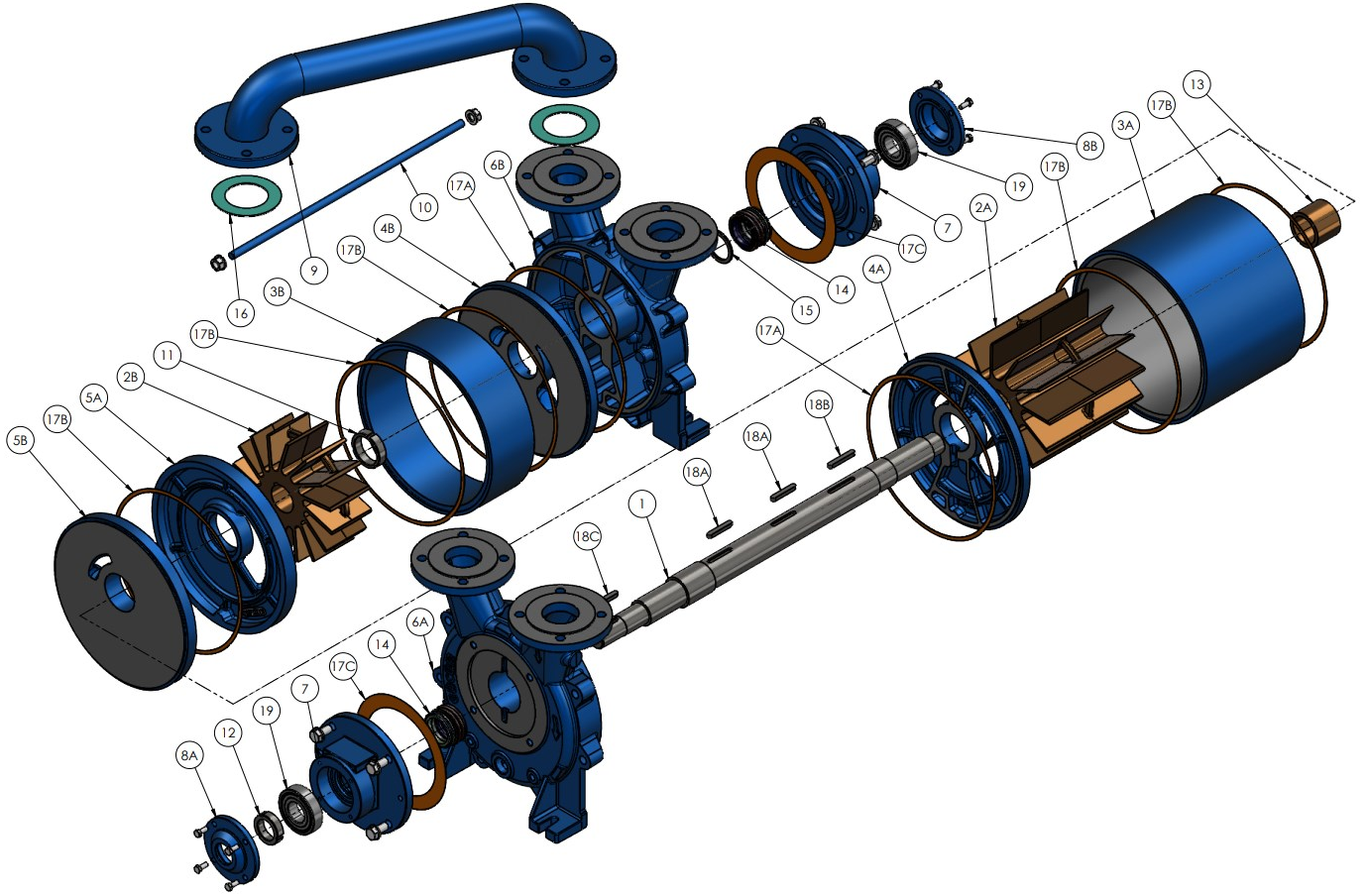

| PART LIST | Cast Iron | Nodular Cast Iron | AISI 420 | AISI 304 | AISI 316 | Bronze | St-37 | Qty. |
|------------------------------|-----------|-------------------|-----------------------------------|----------|----------|--------|-------|------|
| 1.Shaft | | | ✓ | ✓ | ✓ | | | 1 |
| 2A. First Stage Impeller | | | | ✓ | ✓ | ✓ | | 1 |
| 2B. Second Stage Impeller | | | | ✓ | ✓ | ✓ | | 1 |
| 3A. First Stage Cover | | | | ✓ | ✓ | | ✓ | 1 |
| 3B. Second Stage Cover | | | | ✓ | ✓ | | ✓ | 1 |
| 4A. Suction Plate | | ✓ | | ✓ | ✓ | | | 1 |
| 4B. Discharge Plate | | ✓ | | ✓ | ✓ | | | 1 |
| 5A.First Intermediate Plate | | ✓ | | ✓ | ✓ | | | 1 |
| 5B.Second Intermediate Plate | | ✓ | | ✓ | ✓ | | | 1 |
| 6A. Suction Casing | ✓ | | | ✓ | ✓ | | | 1 |
| 6B. Discharge Casing | ✓ | | | ✓ | ✓ | | | 1 |
| 7. Bearing Carrier | ✓ | | | ✓ | ✓ | | | 2 |
| 8A. Bearing Cover | ✓ | | | ✓ | ✓ | | | 2 |
| 8B. Bearing End Cover | | | | | | | | 2 |
| 9. Manifold | | | | ✓ | ✓ | | ✓ | 1 |
| 10. Tie Rod | | | | | | | ✓ | 4 |
| 11. Impeller Nut | | | ✓ | | | | | 1 |
| 12. Bearing Nut | | | ✓ | | | | | 1 |
| 13. Impeller Spacer | | | ✓ | | | | | 1 |
| 14. Mechanical Seal | | | MG1-Ø50-G6 / SiC – Carbon – Viton | | | | | 2 |
| 15. Mechanical Seal Spacer | | | | ✓ | ✓ | | | 1 |
| 16. Klingrite Gasket | | | Klingrite | | | | | 2 |
| 17A. Casing Gasket | | | Paper | | | | | 2 |
| 17B. Cover Gasket | | | Paper | | | | | 4 |
| 17C. Bearing Carrier Gasket | | | Paper | | | | | 2 |
| 18A. Impeller Key | | | | ✓ | ✓ | | ✓ | 1 |
| 18B. Impeller Key | | | | ✓ | ✓ | | ✓ | 1 |
| 18C. Coupling Key | | | | ✓ | ✓ | | ✓ | 1 |
| 19. Bearing | | | 6308-ZZ/C3 / 100Cr6 | | | | | 2 |

CHARACTERISTIC CURVES

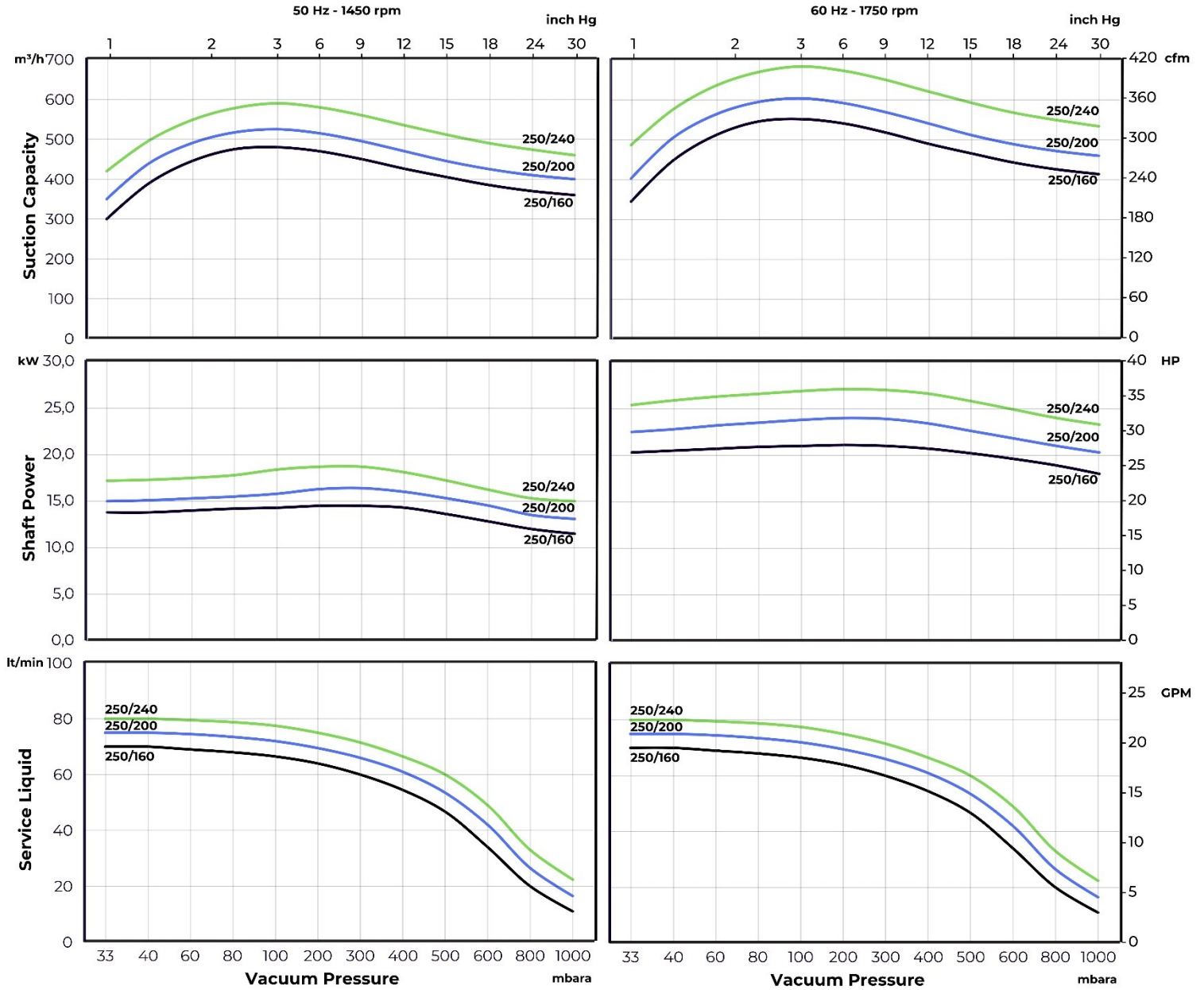

| Type | Suction Capacity | |
|-------------|---|---|
| | 50 Hz | 60 Hz |
| GMP 250/160 | 300 – 480 m ³ /h / 176 – 282 cfm | 345 – 550 m ³ /h / 203 – 324 cfm |
| GMP 250/200 | 350 – 525 m ³ /h / 206 – 309 cfm | 400 – 605 m ³ /h / 235 – 356 cfm |
| GMP 250/240 | 420 – 590 m ³ /h / 247 – 347 cfm | 490 – 685 m ³ /h / 288 – 403 cfm |

The above characteristic curves have been prepared in accordance with ISO 21360 standards. The curves are valid for the vacuum of 15°C service water and 20°C dry air supplied to the liquid ring vacuum pump at atmospheric pressure (760 mmHg / 1013 mbar). The values in the chart have a tolerance of ±10%.

Characteristic curves vary under different operating conditions.