

LIQUID RING VACUUM PUMPS

GVP 230/120 – GVP 230/160 – GVP 230/220

PRESSURE RANGE : 33 – 1013 mbara / 0.98 – 30 inHg

SUCTION CAPACITY : 120 – 480 m³/h / 70 – 283 cfm

GÜCÜM two stage liquid ring vacuum pumps are used for pumping dry and wet gases, small quantities of liquid can be handled. They are used in the areas at which vacuum needed between the pressures 1013 to 33 mbar

Güçüm Two stage liquid ring vacuum pumps have below features;

- Able to pump every kind of gases and vapors,
- Able to handle small quantities of liquid with gases,
- Oil-free, no need to lubrication,
- Pumped gas does not touch to oil,
- Minimum maintenance with high efficiency
- No metallic contact of the rotating parts,
- Works quiet and reduced vibration,
- Nearly everywhere used with suitable material choices.



APPLICATION

Pumps are used for the discharge of dry and humid gases (containing vapor) and a certain amount of water. It can be used in all areas where absolute pressure between 1013 and 33 mbar is required.

ADDITIONAL NOTE

During operation, the pump must be continuously supplied with liquid (usually water) to replenish the water from the exhaust line and to reduce the pump temperature. The water discharged from the pump is separated from the gas and is suitable for reuse.

The direction of shaft rotation is clockwise when viewed from the motor side.
The tightness is ensured by a standard mechanical seal.

TECHNICAL FEATURES		
Maximum allowable pressure differential	1.1	bar
Highest saturated air temperature	100	°C
Highest dry air temperature	200	°C
Highest service water temperature	70	°C
Highest service water viscosity	4	mm ² /sec
Noise level (at 80 mbar vacuum)	66 ±3	dB A
Highest density of service water	1200	kg/m ³
Highest heat exchanger flow resistance	0,2	bar

OVERALL DIMENSIONS

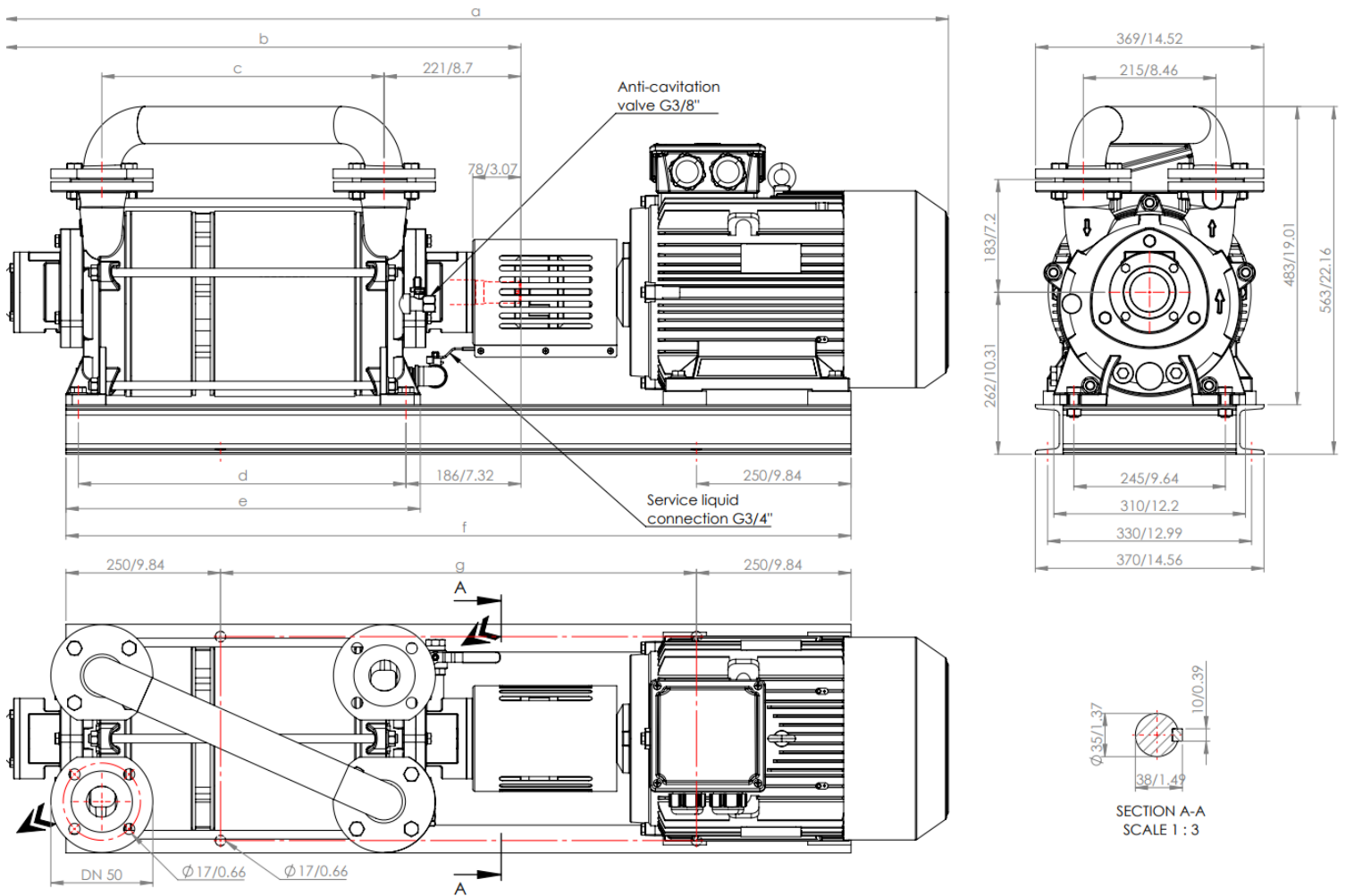

MODEL	50 Hz.	a	b	c	d	e	f	g	Weight (kg / lbs)	
		mm / inch							Bare Shaft	With Motor
GVP 230/120		1380 / 54.33	735 / 28.93	357 / 14.05	430 / 16.92	475 / 18.7	1120 / 44.09	620 / 24.4	140 / 309	260 / 573
GVP 230/160		1420 / 55.90	775 / 30.51	397 / 15.62	470 / 18.5	515 / 20.27	1160 / 45.66	660 / 25.98	156 / 344	280 / 617
GVP 230/220		1530 / 60.23	835 / 32.87	457 / 17.99	530 / 20.86	575 / 22.63	1270 / 50	770 / 30.31	175 / 386	320 / 705

MODEL	60 Hz.	a	b	c	d	e	f	g	Weight (kg / lbs)	
		mm / inch							Bare Shaft	With Motor
GVP 230/120		1430 / 56.29	735 / 28.93	357 / 14.05	430 / 16.92	475 / 18.7	1170 / 46.06	670 / 26.37	140 / 309	280 / 617
GVP 230/160		1470 / 57.87	775 / 30.51	397 / 15.62	470 / 18.5	515 / 20.27	1210 / 47.63	710 / 27.95	156 / 344	300 / 661
GVP 230/220		1575 / 62	835 / 32.87	457 / 17.99	530 / 20.86	575 / 22.63	1270 / 50	770 / 30.31	175 / 386	345 / 760

Motor Specifications										
Type	50 Hz		60 Hz		50 Hz			60 Hz		
	Frame Size – Flange Type		Frame Size – Flange Type		rpm	kW	HP	rpm	kW	HP
GVP 230/120	160M – B3		160L – B3		1450	11	15	1750	15	20
GVP 230/160	160M – B3		160L – B3		1450	11	15	1750	15	20
GVP 230/220	160L – B3		180M – B3		1450	15	20	1750	18.5	25

EXPLODED VIEW AND PART LIST

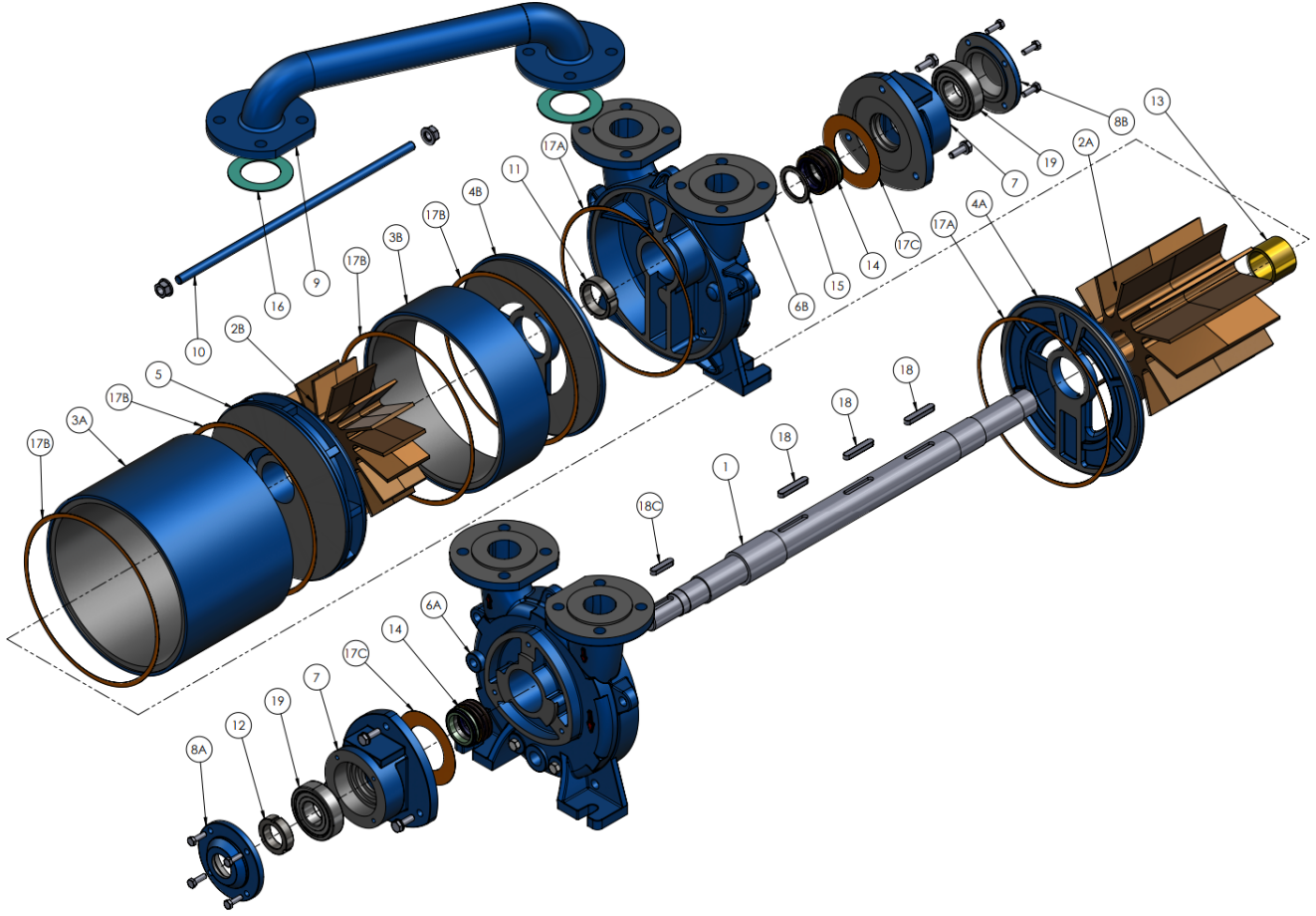

PART LIST	Cast Iron	Nodular Cast Iron	AISI 420	AISI 304	AISI 316	Bronze	St-37	Qty.
1. Shaft			✓	✓	✓			1
2A. First Stage Impeller				✓	✓	✓		1
2B. Second Stage Impeller				✓	✓	✓		1
3A. First Stage Cover				✓	✓		✓	1
3B. Second Stage Cover				✓	✓		✓	1
4A. Suction Plate		✓		✓	✓			1
4B. Discharge Plate		✓		✓	✓			1
5. Intermediate Plate		✓		✓	✓			1
6A. Suction Casing	✓			✓	✓			1
6B. Discharge Casing	✓			✓	✓			1
7. Bearing Carrier	✓			✓	✓			2
8A. Bearing Cover	✓			✓	✓			2
8B. Bearing End Cover								2
9. Manifold				✓	✓		✓	1
10. Tie Rod							✓	4
11. Impeller Nut			✓					1
12. Bearing Nut			✓					1
13. Impeller Spacer			✓					1
14. Mechanical Seal			MG1 – Ø45 – G6 / SiC – Carbon – Viton					2
15. Mechanical Seal Spacer				✓	✓			1
16. Klingrite Gasket				Klingrite				2
17A. Casing Gasket				Paper				2
17B. Cover Gasket				Paper				4
17C. Bearing Carrier Gasket				Paper				2
18. Impeller Key				✓	✓		✓	3
18C. Coupling Key				✓	✓		✓	1
19. Bearing			6308-ZZ/C3 / 100Cr6					2

CHARACTERISTIC CURVES

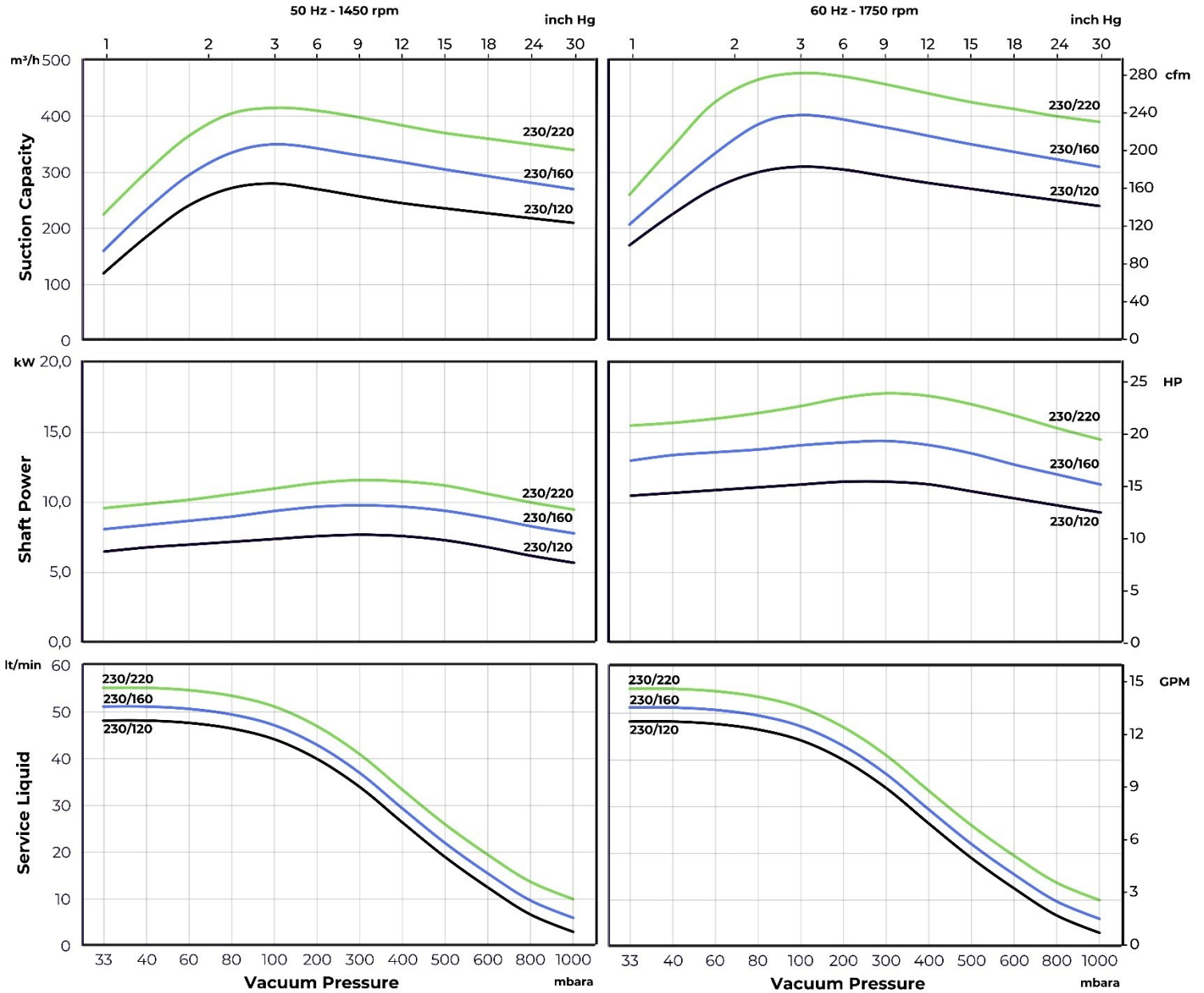

Type	Suction Capacity	
	50 Hz	60 Hz
GVP 230/120	120 – 280 m ³ /h / 70 – 165 cfm	170 – 310 m ³ /h / 100 – 183 cfm
GVP 230/160	160 – 350 m ³ /h / 95 – 206 cfm	205 – 400 m ³ /h / 120 – 235 cfm
GVP 230/220	225 – 415 m ³ /h / 132 – 245 cfm	260 – 480 m ³ /h / 153 – 283 cfm

The above characteristic curves have been prepared in accordance with ISO 21360 standards. The curves are valid for the vacuum of 15°C service water and 20°C dry air supplied to the liquid ring vacuum pump at atmospheric pressure (760 mmHg / 1013 mbar). The values in the chart have a tolerance of ±10%.

Characteristic curves vary under different operating conditions.