

# LIQUID RING VACUUM PUMPS

Two Stage GVP 275/160 - GVP 275/220 - GVP 275/260

**Pressure Range : 33 - 1013 mbar**  
**Suction Capacity : 410 - 860 m<sup>3</sup>/h**



GÜCÜM Two Stage Liquid Ring Vacuum Pumps are used for pumping dry and wet gases, small quantities of liquid can be handled. They are used in the areas at which vacuum needed between the pressures 1013 to 33 mbar.

GÜCÜM Two Stage Liquid Ring Vacuum Pumps have the below features:

- \* Able to pump every kind of gases and vapours,
- \* Able to handle small quantities of liquid with gases,
- \* Oil-free, no need to lubrication,
- \* Pumped gas do not touch the oil,
- \* Minimum maintenance with high efficiency,
- \* No metallic contact of the rotating parts,
- \* Works quiet and reduced vibration,
- \* Nearly everywhere used with suitable material choices.

## Service Liquid

During pump working, service liquid must be supplied to replenish the liquid ring and to cool the pump (generally water is used). The exhausted liquid could be used again after separating the gas inside of it.

The direction of the rotation is clockwise, when looking from the motor on the pump.

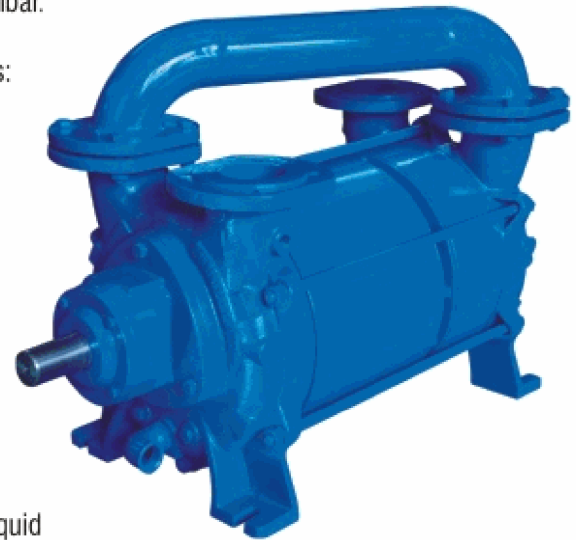

## TECHNICAL PROPERTIES

Properties	Unit	GVP 275/160	GVP 275/220	GVP 275/260
Motor Power	kW	18,5	22	30
Motor Speed	rpm	1450		
Max. Service liquid flow	lt/min	50	60	65
Max. Admissible pressure difference	bar	1,1		
Max. Gas temperature	°C	100		
Max. Service liquid temperature	°C	70		
Max. Service liquid viscosity	mm <sup>2</sup> /s	4		
Sound pressure level (at 80 mbar suc. pressure)	dB A	80 ±3		
Max. Service liquid density	kg/m <sup>3</sup>	1200		
Max. Flow resistance of the heat exchanger	bar	0,2		

# OVERALL DIMENSIONS

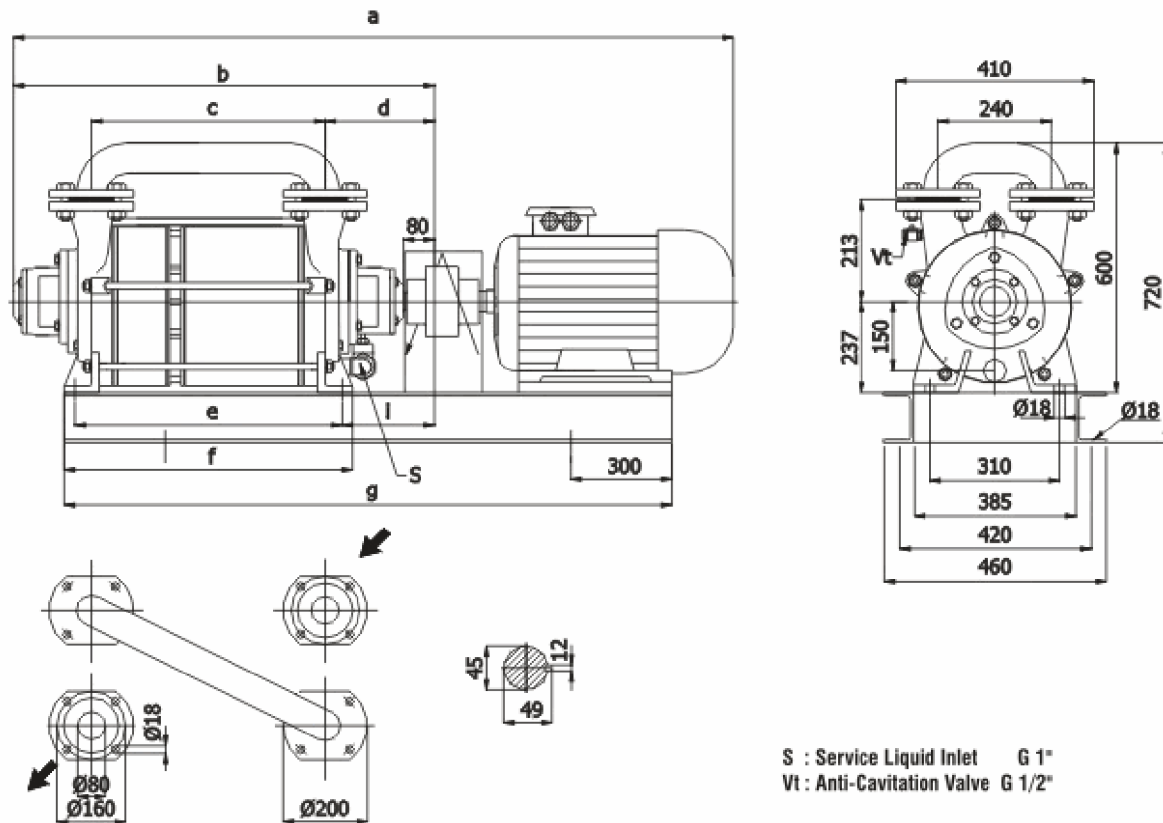

MODEL	a	b	c	d	e	f	g	i	Weight (bare shaft) kg	Weight (complete with motor) kg
GVP 275/160	1530	855	420		500	540	1270		225	465
GVP 275/220	1640	925	490	255	570	610	1380	215	255	520
GVP 275/260	1740	975	540		620	660	1470		275	590

## MATERIALS

Part Name	Standard Construction	Stainless Steel Construction
Suction&Discharge Casing	GG 25 Cast Iron	AISI 304-AISI 316 St. Steel
Plates	GGG 40 Sph. Cast Iron	AISI 304-AISI 316 St. Steel
Body	GGG 40 Sph. Cast Iron	AISI 304-AISI 316 St. Steel
Shaft	AISI 420 Stainless Steel	AISI 304-AISI 316 St. Steel
Impellers	G Cu Sn 9 Bronze	AISI 304-AISI 316 St. Steel
Mechanical Seal	Si. Carbide/ Carbon/Viton	Cr Ni Mo Steel/Carbon/Viton

# SECTIONAL DRAWING AND PART LIST

GVP 275/160 - GVP 275/220 - GVP 275/260

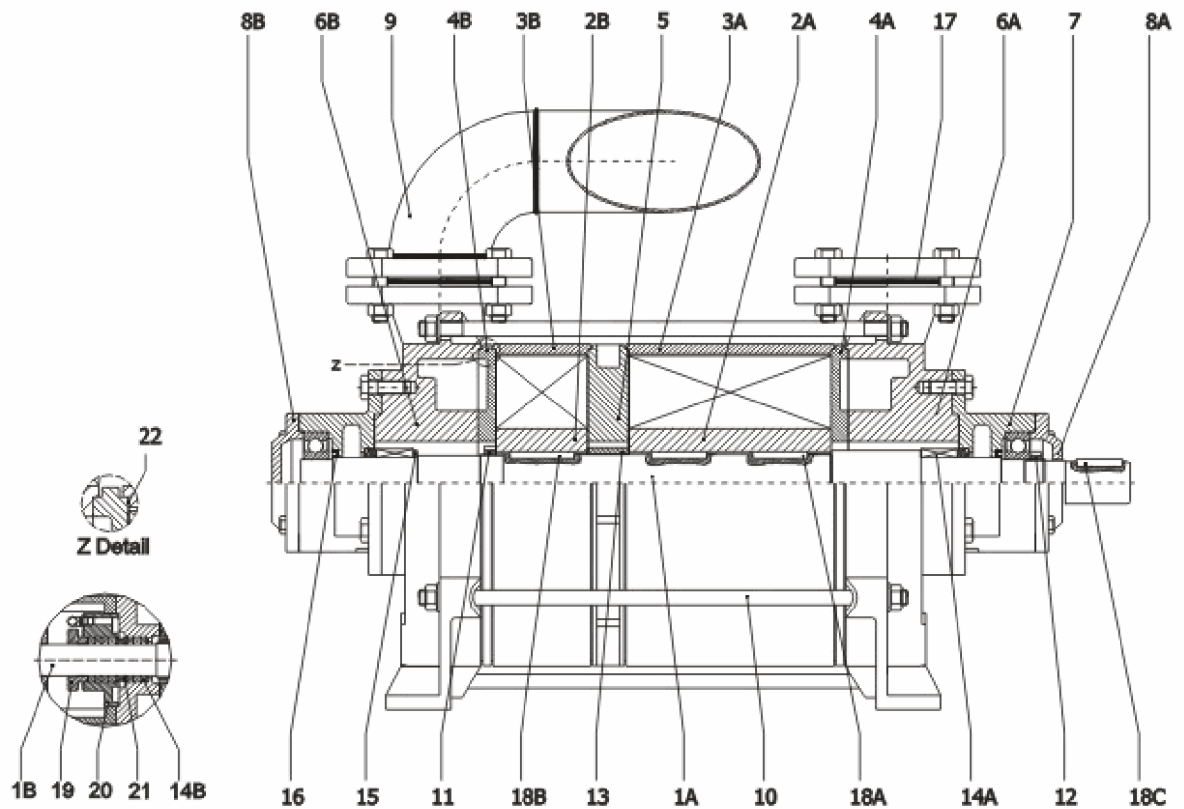

No	Part Name	No	Part Name
1A	Shaft (Mechanical Seal)	11	Impeller Nut
1B	Shaft (Soft Packing)	12	Bearing Nut
2A	First Impeller	13	Impeller Spacer
2B	Second Impeller	14A	Mechanical Seal
3A	First Casing	14B	Soft Packing
3B	Second Casing	15	Mech. Seal Spacer
4A	Suction Plate	16	O-ring
4B	Discharge Plate	17	Gasket
5	Intermediate Plate	18A	First Impeller Key
6A	Suction Casing	18B	Second Impeller Key
6B	Discharge Casing	18C	Coupling Key
7	Bearing Carrier	19	Gland
8A	Bearing Cover	20	Stuffing Box
8B	Bearing End Cover	21	Lantern Ring
9	Branch Pipe	22	Paper Gasket
10	Tie Rod		



# CHARACTERISTIC CURVES

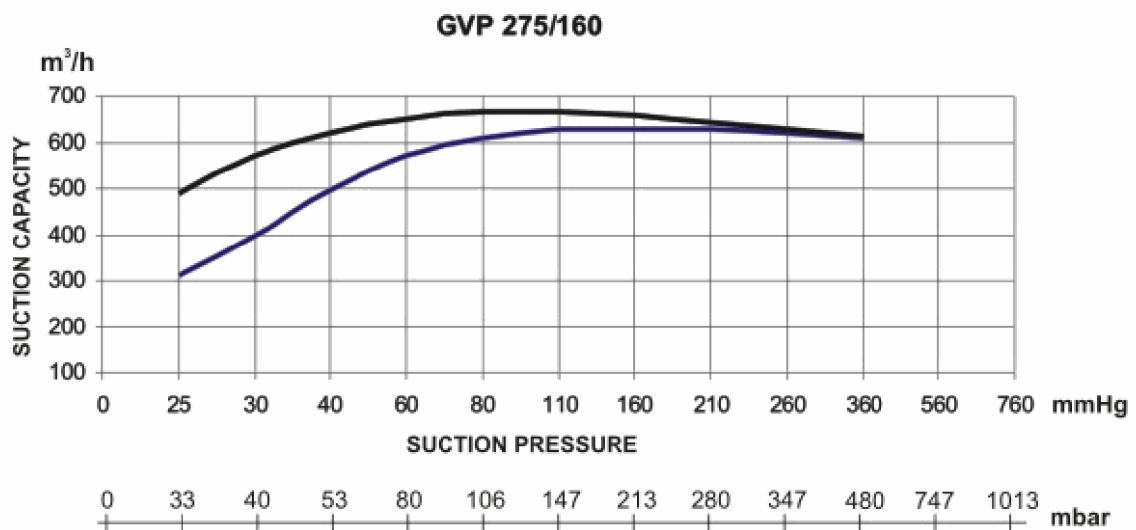
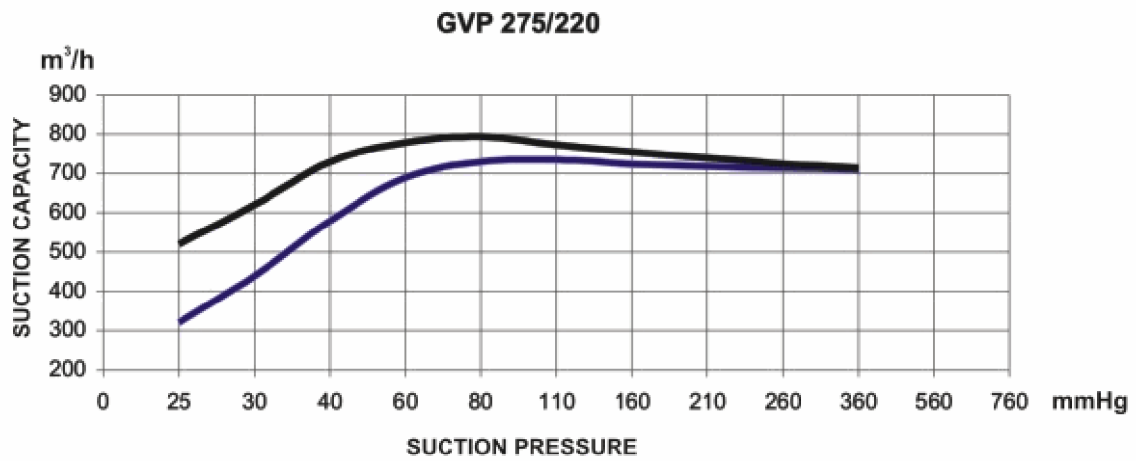
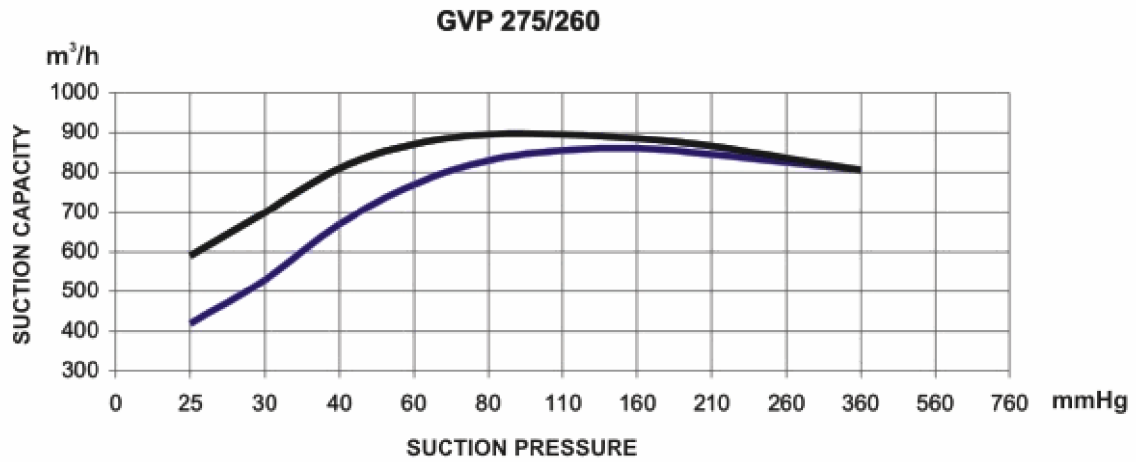

20 °C water vapour saturated air
  20 °C dry air

The capacities shown at the graph are for 760 mmHg atmosphere pressure and service liquid temperature 15 °C . Tolerance of the curves are 10% .